

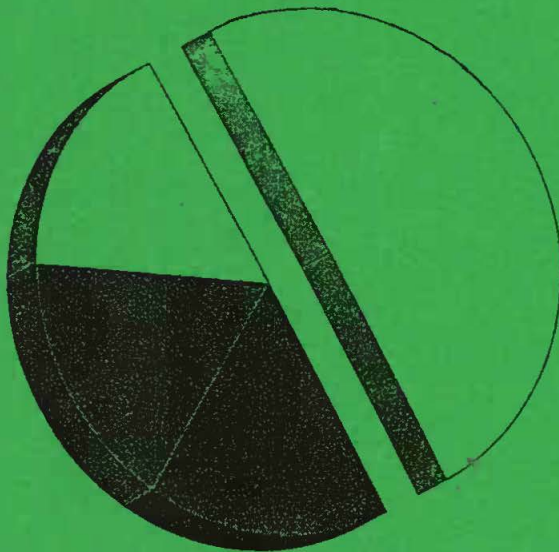

Volume 32, Number 3

August 1995



1	2	3	4	5	6	7	8	9	10
11	12	13	14	15	16	17	18	19	20
21	22	23	24	25	26	27	28	29	30
31	32	33	34	35	36	37	38	39	40
41	42	43	44	45	46	47	48	49	50
51	52	53	54	55	56	57	58	59	60
61	62	63	64	65	66	67	68	69	70
71	72	73	74	75	76	77	78	79	80
81	82	83	84	85	86	87	88	89	90
91	92	93	94	95	96	97	98	99	100

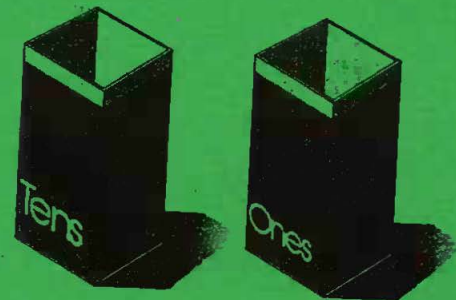
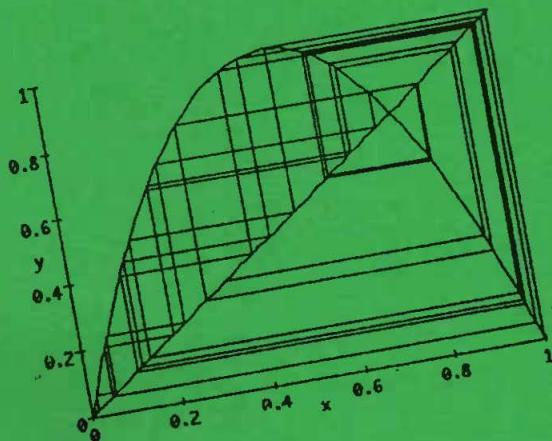
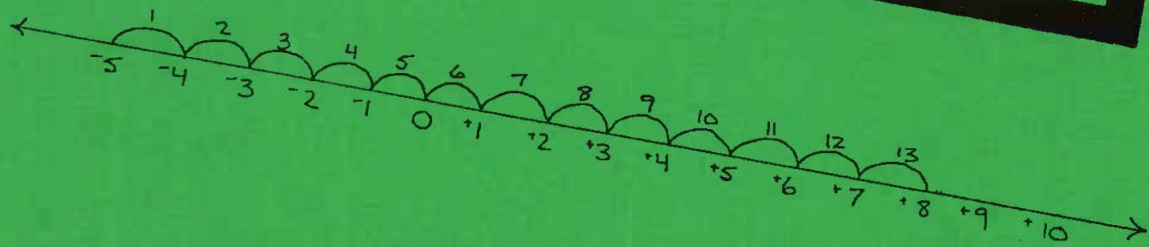

CONTENTS

Comments on Contributors	2	
Editorial	3	<i>Arthur Jorgensen</i>
The 100s Chart: A Stepping Stone to Mental Mathematics	4	<i>Carol A. Thornton, Graham A. Jones and Judy L. Neal</i>
Exploring Products Through Counting Digits: Equal Factors	7	<i>W. George Cathcart</i>
Developing and Assessing Understanding of Integer Operations	10	<i>Jim Vance</i>
Maple: A Computer Algebra System	15	<i>John Heuver</i>
Area Graphs from Area Formulas: Connecting Geometry and Algebra	19	<i>Bonnie H. Litwiller and David R. Duncan</i>
Building a Professional Memory: Articulating Knowledge About Teaching Mathematics	21	<i>Barry Onslow and Art Geddis</i>
Writing Mathematics	24	<i>E.G. Bernard</i>

Copyright © 1995 by The Alberta Teachers' Association (ATA), 11010 142 Street NW, Edmonton, Alberta T5N 2R1. Permission to use or to reproduce any part of this publication for classroom purposes, except for articles published with permission of the author and noted as "not for reproduction," is hereby granted. *delta-K* is published by the ATA for the Mathematics Council (MCATA). EDITOR: Arthur Jorgensen, 4411 5 Avenue, Edson, Alberta T7E 1B7. EDITORIAL AND PRODUCTION SERVICES: Central Word Services staff, ATA. Opinions expressed herein are not necessarily those of MCATA or of the ATA. Address correspondence regarding this publication to the editor. *delta-K* is indexed in the Canadian Education Index. ISSN 0319-8367

COMMENTS ON CONTRIBUTORS

Carol A. Thornton is a distinguished professor and *Graham A. Jones* is a visiting professor at Illinois State University, Normal, Illinois.

Judy L. Neal teaches at Irving Elementary School, Bloomington, Illinois.

W. George Cathcart is a professor in the Faculty of Education at the University of Alberta.

Jim Vance is a professor in the Faculty of Education at the University of British Columbia.

John Heuver teaches at Grande Prairie Composite High School.

Bonnie H. Litwiller and *David R. Duncan* are professors of mathematics at the University of Northern Iowa, Cedar Falls, Iowa.

Barry Onslow and *Art Geddis* are professors in the Faculty of Education at the University of Western Ontario in London.

E.G. Bernard is a vice principal at Marc Garneau Collegiate Institute in Don Mills, Ontario.

delta-K is the official journal of the Mathematics Council (MCATA) of The Alberta Teachers' Association (ATA).

The objective of the *Journal* is to assist MCATA to achieve its objective of improving teaching practices in mathematics by publishing articles that increase the professional knowledge and understanding of teachers, administrators and other educators involved in teaching students mathematics. The *Journal* seeks to stimulate thinking, to explore new ideas and to offer various viewpoints. It serves to promote MCATA's convictions about mathematics education.